

Installation Instructions

SERVICE REFERENCE

DIVISION 4	SECTION RT
SALES REFERENCE	PJ912
161-562425-001	
DATE	JUNE, 2009

Type HL-PC Hazardous Location Power Connection Kit for Self-Regulating Heating Cables

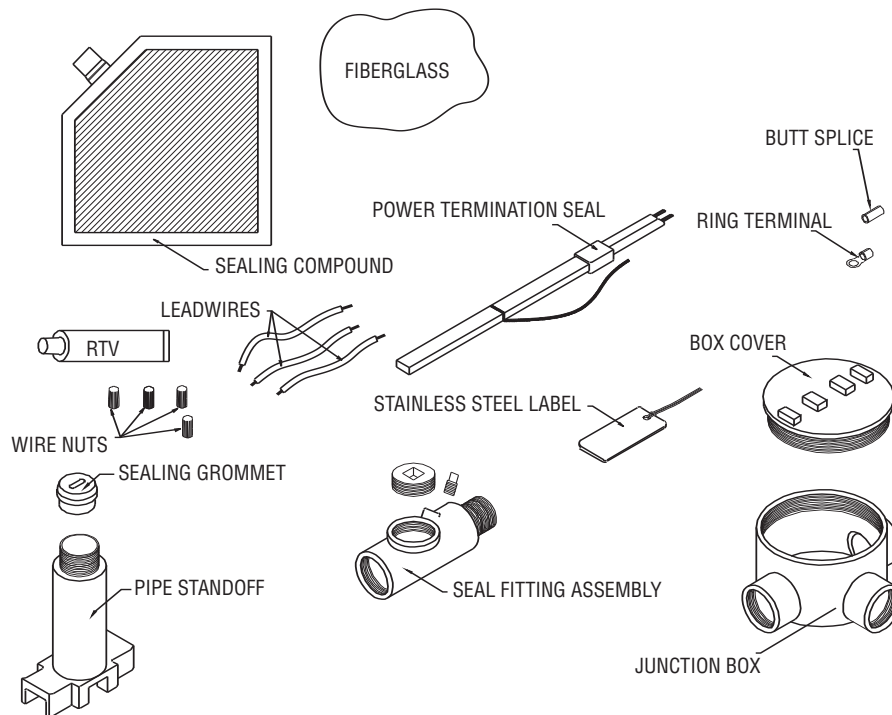

HL-PC Kit Parts:

Qty	Description
1	3/4" Box
1	3/4" Conduit plug
1	3/4" Seal fitting with nipple
1	Sealing compound & fiber
1	Small RTV tube
2	Power termination seal
1	Pipe stand-off
1	Butt splice
1	Sealing grommet
2	4" 12 AWG leadwire white
1	Stainless steel label
4	Wire nuts
1	4" 12 AWG leadwire green

GENERAL

The HL-PC hazardous location power connection kit is used for electrical termination of self-regulating cables in hazardous Division 1 areas. Each kit contains the terminations and explosion

proof seal parts needed to make all electrical connections. Panduit CT-100 crimping tool or equivalent required.

INSTALLATION

⚠ WARNING

Hazard of Electric Shock. Disconnect all power before starting. All installations must be effectively grounded in accordance with the National Electrical Code to eliminate shock hazard.

⚠ WARNING

The system designer is responsible for the safety of this equipment and should install adequate back-up controls and safety devices with their electric heating equipment. Where the consequences of failure could result in personal injury or property damage, back-up controls are essential.

⚠ WARNING

Explosion Hazard. Turn off power before removing junction box cover at all times.

1. Mount the stand-off to the pipe using pipe straps (not included). Allow 7 inches of heating cable for the termination. Leave an extra 12 inches of heating cable to compensate for heat loss of the connection kit. Slide the sealing grommet over the heating cable and position the grommet in the stand-off.

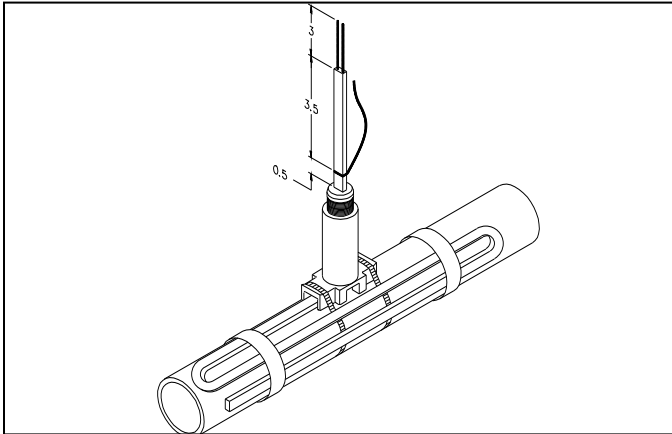

Overjacket Stripping Procedure

2. Score the outer insulation 7 inches from the end of the cable. Lightly cut the outer jacket up the center to the end of heating cable and remove the outer jacket from the cable.

⚠ WARNING

Do not cut through metal braid. Effective ground cannot be established if the metal braid is removed.

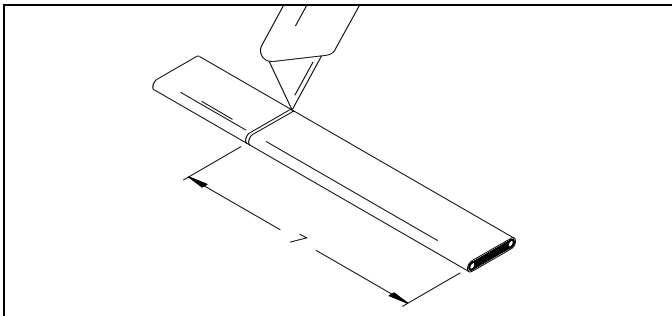

3. Move braid back toward the overjacket, creating a bulge.

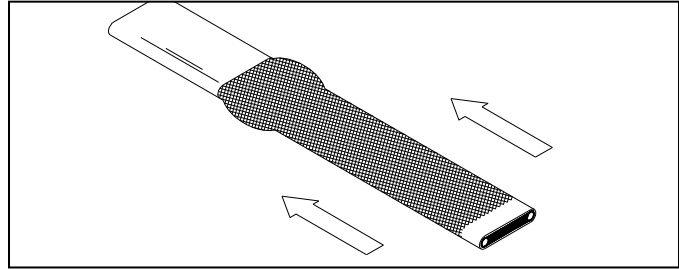

4. At the bulge, separate the braid to make an opening.

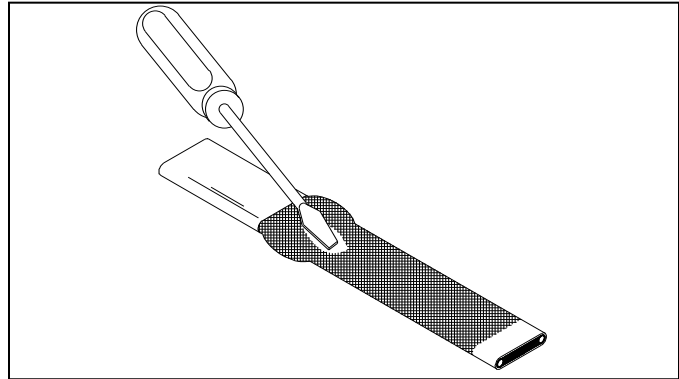

5. While bending the heating cable, work the cable through the braid opening. Pull the braid tight.

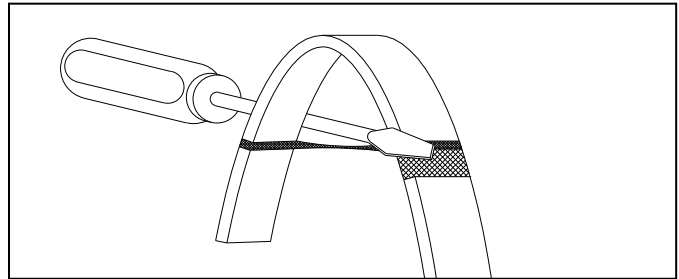

6. Score the inner insulation 3 1/2 inches from the end. Lightly cut the inner jacket up the center to end of heating cable and remove the inner jacket from the cable.

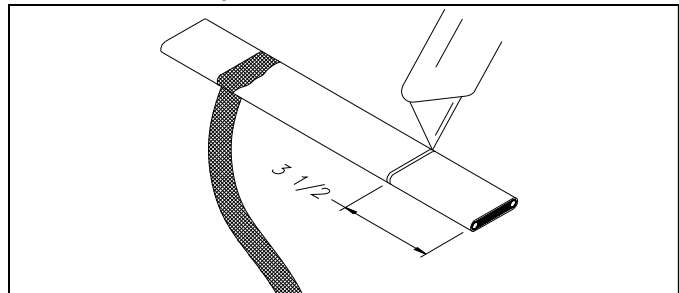

7. Shave the core material from the outside of each bus wire.

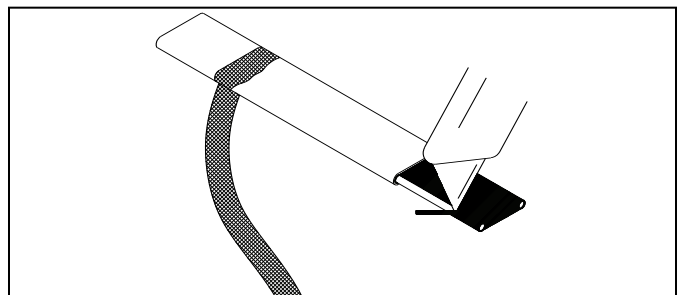

INSTALLATION (cont'd.)

8. Starting at the end of the heating cable, pull each bus wire away from the core material.

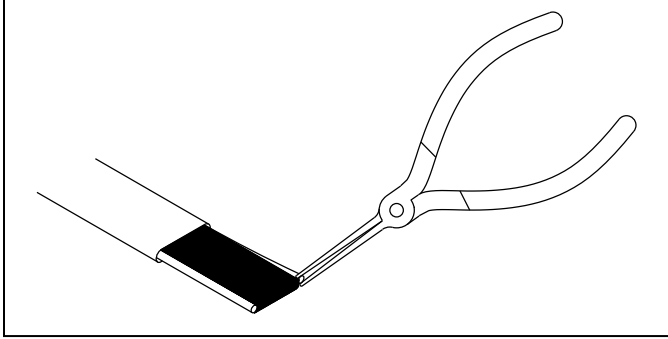

9. Remove the exposed core material and cut 1/4" off the end of each bus wire.

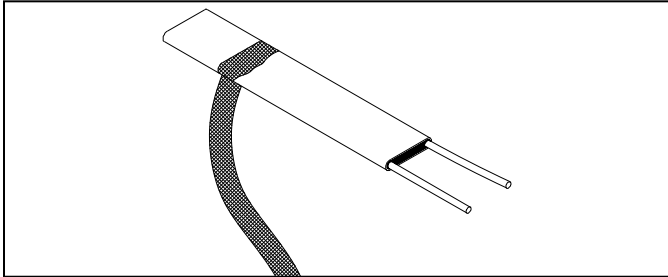

10. Liberally apply RTV over the exposed matrix and leads. Push the rubber boot over the heating cable. Trim lead ends as needed.

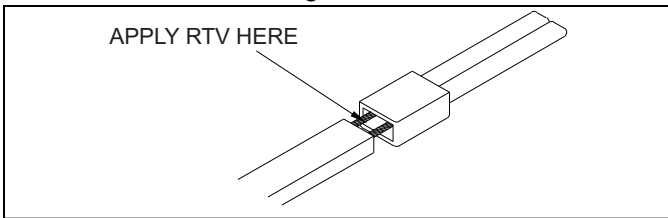

11. Slide the seal fitting over the heater cable and braid, screw onto the stand-off by hand until snug.

Note: The heating cable must be positioned in the seal fitting so the braid transition point is visible through the seal fitting opening. See sheet 7.

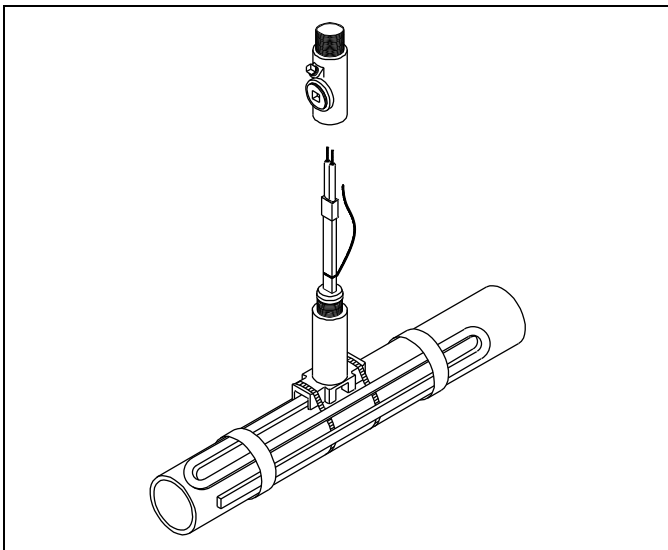

12. Slide the male adapter over the heating cable and braid, screw on seal fitting by hand. Tighten to a minimum of 5 full threads of engagement.

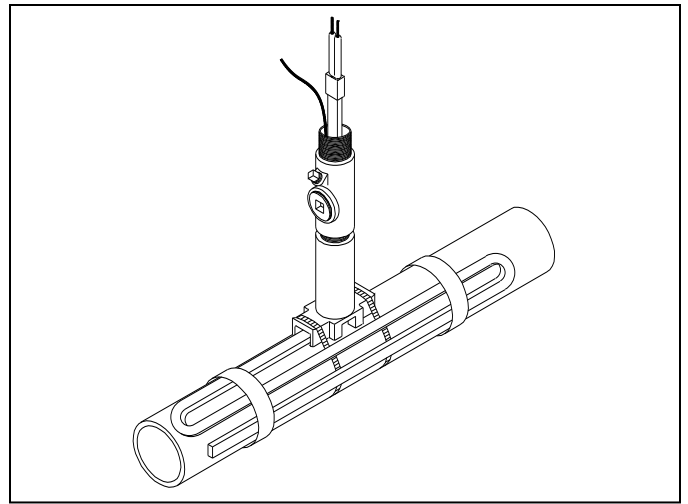

13. Place the junction box over the heating cable and braid, screw on male adapter until snug. Tighten to a minimum of 5 full threads of engagement.

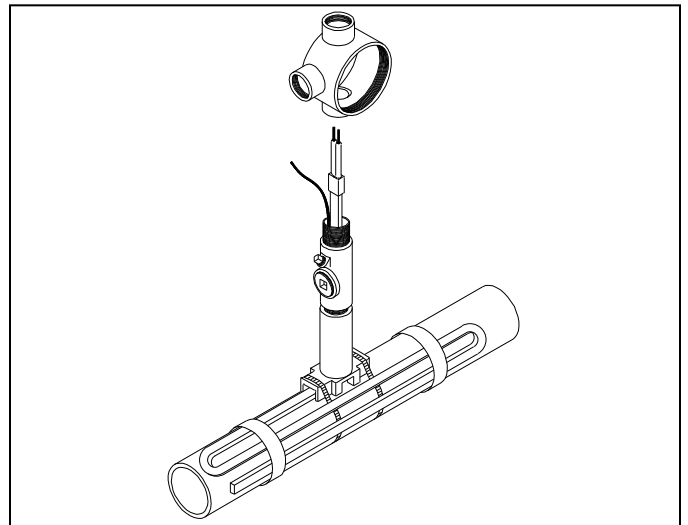

14. Wire nut the bus wires to the 12AWG leads. Connect the grounding braid to the green grounding lead provided with the butt splice. Crimp the ring tongue to the grounding lead and attach terminal to the junction box. Tighten to a minimum of 5 full threads of engagement.

15. Thread the box cover gasket, box cover, and conduit plug onto the junction box.

Sealing compound

16. Center the heating cable in the conduit opening. See sheet 7. Using the fiber included, pack around the heating cable forming a dam to hold the sealing compound.

INSTALLATION (cont'd.)

17. Mix the sealing compound according to the instructions on the pouch. Fill the seal fittings.

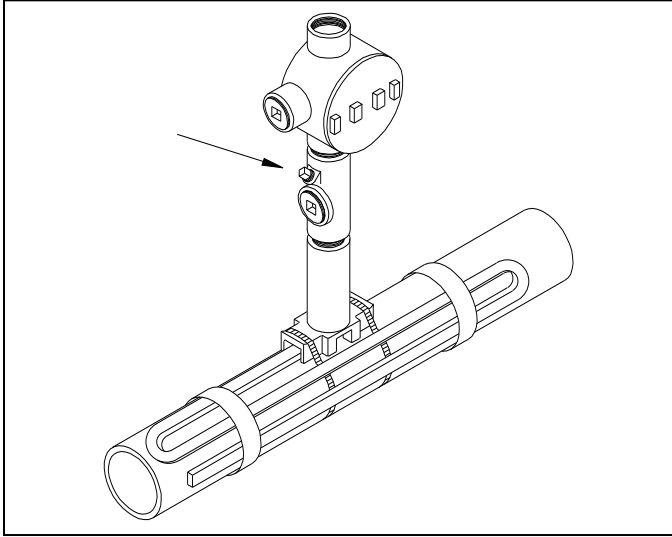

18. Attach stainless steel label with wire ties wrapping around kit between seal fitting and junction box.

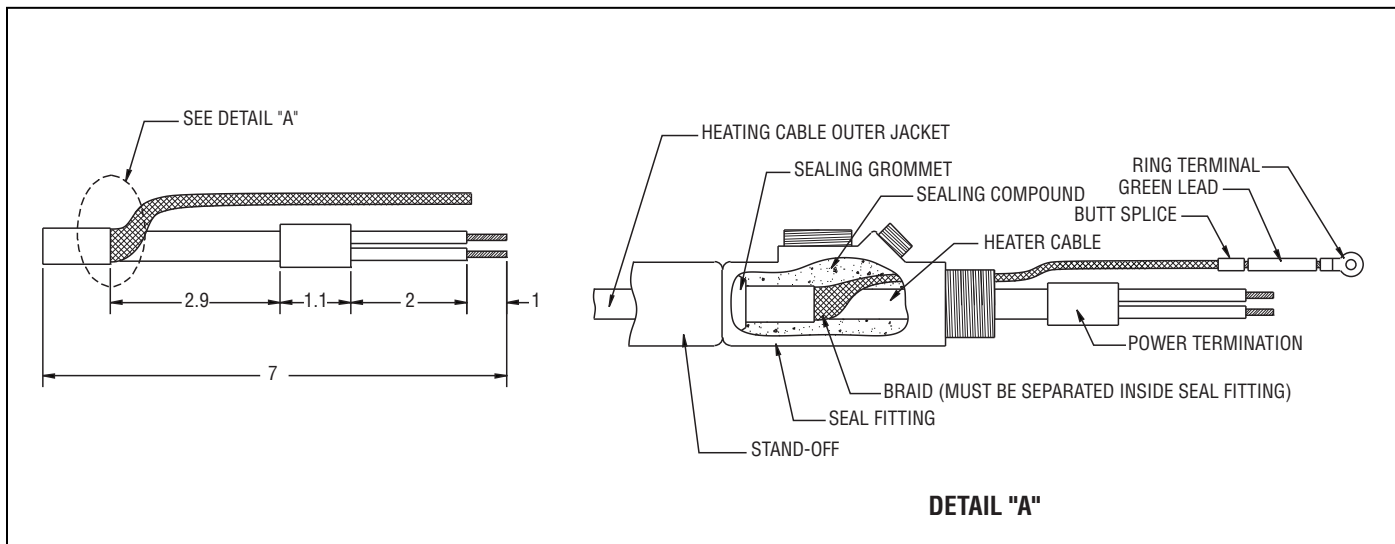

Limited Warranty:
Please refer to the Chromalox limited warranty applicable to this product at
<http://www.chromalox.com/customer-service/policies/termsforsale.aspx>.

Chromalox[®]
PRECISION HEAT AND CONTROL

1347 HEIL QUAKER BLVD., LAVERGNE, TN 37086
Phone: (615) 793-3900 www.chromalox.com